

## **Technical Report**

# **Experimental Studies on Rolling Shear Strength properties of Douglas-fire CLT and Monotonic Behaviour of Dowelled Connections**

**Authors:  
Minghao Li  
Justin Brown  
Wenchen Dong**

**University of Canterbury**

Date: 25 June 2018

Report: SWP-T053

## **Disclaimer**

This report has been prepared by University of Canterbury for Forest Growers Research Ltd (FGR) subject to the terms and conditions of a research services agreement dated 1 July 2015.

The opinions and information provided in this report have been provided in good faith and on the basis that every endeavour has been made to be accurate and not misleading and to exercise reasonable care, skill and judgement in providing such opinions and information.

Under the terms of the Services Agreement, University of Canterbury's liability to FGR in relation to the services provided to produce this report is limited to the value of those services. Neither University of Canterbury nor any of its employees, contractors, agents or other persons acting on its behalf or under its control accept any responsibility to any person or organisation in respect of any information or opinion provided in this report in excess of that amount.

## TABLE OF CONTENTS

EXECUTIVE SUMMARY .....	1
1. INTRODUCTION .....	2
2. DESCRIPTION OF D.FIR CLT SPECIMENS .....	5
3. DESCRIPTION OF TEST PROGRAMME .....	7
3.1 Short Bending Testing .....	7
3.2 Embedment Strength Testing .....	8
3.3 Monotonic Dowelled Connection Testing .....	9
3.4 Cyclic Dowelled Connection Testing .....	10
3.5 Analytical Strength Predictions of Dowelled Connections .....	11
4. EXPERIMENTAL RESULTS .....	12
4.1 Short Bending Testing .....	12
4.2 Embedment Strength Testing .....	14
4.3 Monotonic Dowelled Connection Testing .....	16
4.4 Cyclic Dowelled Connection Testing .....	24
5. CONCLUSIONS.....	25
ACKNOWLEDGEMENTS .....	26
REFERENCES .....	27
APPENDIX A DOWELLED CONNECTION DRAWINGS .....	28

## **Executive Summary**

Cross laminated timber (CLT) production and research in NZ is currently dominated by Radiata pine. However, there is a significant resource of Douglas-fir (D.Fir) available in NZ, not widely processed on-shore. CLT is a potential high-value building product for the D.Fir resource but some important mechanical properties of D.Fir CLT and the associated connection behaviour remain largely unknown. Thus, there is a need to establish a comprehensive database of the mechanical properties and connection behavior of D.Fir CLT in order for designers to specify D.Fir CLT in building design.

In this project, two important design properties for D.Fir CLT, i.e., rolling shear (RS) strength and embedment strength, were evaluated by short-span bending tests and embedment tests following standard test methods. Commonly used dowelled hold-down connections in CLT buildings were also tested to evaluate the critical connection behavior in terms of strength, stiffness, and ductility. The test results showed that the D.Fir CLT specimens demonstrated good RS and embedment properties and the dowelled connections also showed reliable behavior with high strength and stiffness and superior ductility.

## **1. INTRODUCTION**

Emerging timber technologies, environmental awareness, increased urbanization, and the architectural desire for aesthetically pleasing structurally exposed building interiors have led to increased interest in timber research and construction. Timber is experiencing a renaissance as a building material, supported by innovative fabrication and construction technologies which produce engineered wood products (EWPs) to a high level of prefabrication allowing for efficient and safe installation. New construction with EWPs around the world confirms that timber buildings are a cost-effective, timely solution when chosen for a suitable building occupancy. The International Panel on Climate Change has identified that a building's construction and service life are major contributors to global emissions, accounting for as much as 50% in some developed countries (Pachauri & Reisinger, 2007).

In New Zealand (NZ), and worldwide, population is shifting to more urban environments. Page (2017) shows in BRANZ Study Report 379 that medium-density housing demand will continue to rise, with the primary construction material for taller medium-density units still being steel and concrete. Increased urbanization presents an opportunity to respond with sustainable, environmentally friendly and cost efficient timber construction. As stated by renowned timber proponent architect Michael Green, a systemic change is necessary in the building industry to combat climate change, and timber is a viable solution (Green, 2017).

One of most commonly used EWPs in the market today is Cross-laminated timber (CLT). Worldwide production of CLT is experiencing exponential growth, as shown in Figure 1 below.

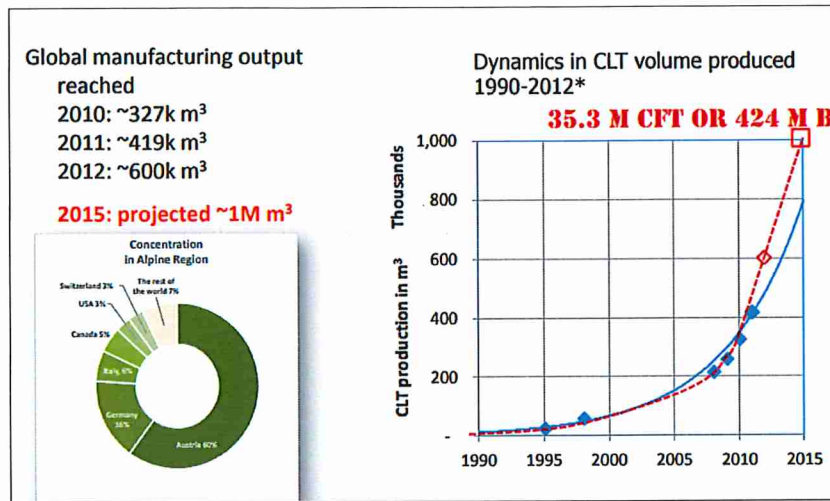

Figure 1: Worldwide CLT Production (m<sup>3</sup>/year)  
sources: for period 1990-2010, Schickhofer (2011); for period 2011-2015, Muszyński (2015)

The 1 million m<sup>3</sup>/year projected production target was reached in 2015, and it is predicted that world production will grow to 3 million m<sup>3</sup>/year in the next 8 years. CLT is gaining more popularity in NZ due to its superior properties compared with conventional timber products. A number of multi-storey CLT buildings have been built in NZ such as the Bealey Backpackers Hostel shown in Figure 2 below.

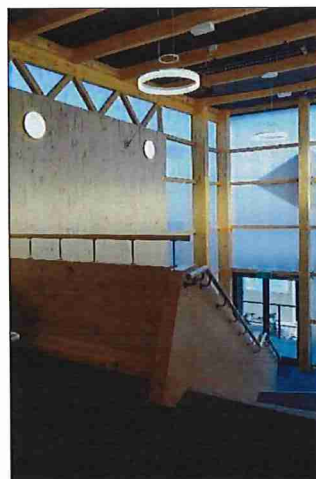

Figure 2: Bealey Backpackers Hostel  
Fundamental mechanical properties of D.Fir CLT are required for design engineers to specify the product in building construction. These properties include rolling shear properties and embedment

strength properties. The rolling shear strength is needed to design CLT in short-span beam applications and other loading scenarios when high shear stresses are introduced in cross layers of CLT since wood has very low rolling shear strength and stiffness. Embedment strength is another important property required to design timber connections using dowel-type fasteners, such as nails, dowels and bolts. In multi-storey CLT buildings, dowelled hold-down connections are commonly used to prevent overturning caused by wind and seismic. This is shown schematically in Figure 3 where the vertical forces with arrows are located, and in practice in Figure 4.

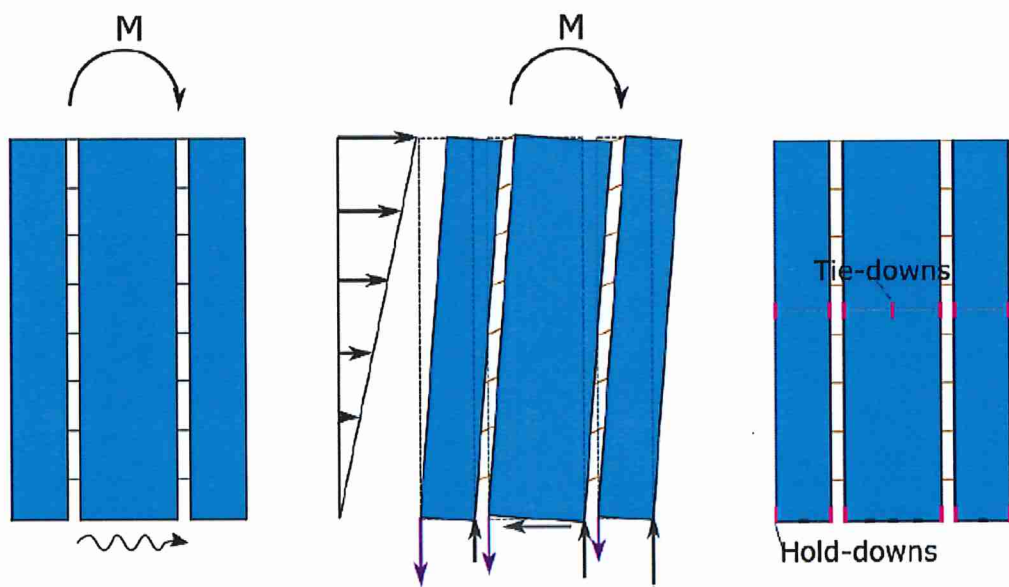

Figure 3: Dowelled Hold-down Connection Motivation (c/o Lisa Ottenhaus)

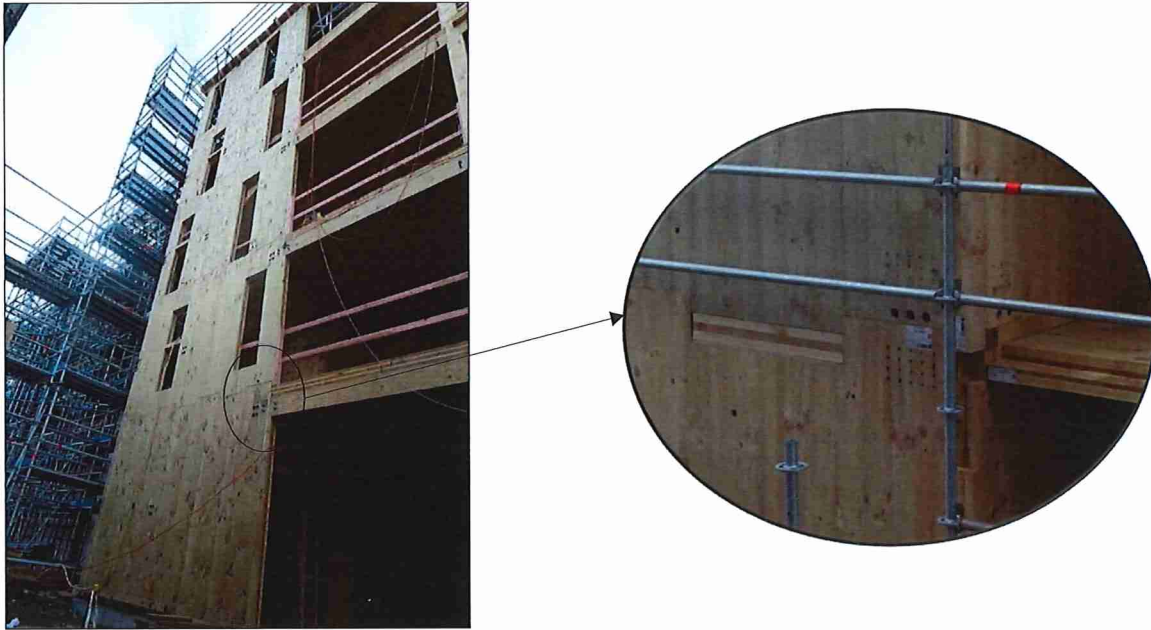

Figure 4: Otago Polytechnic Building Dowelled Connection

## 2. DESCRIPTION OF D.FIR CLT SPECIMENS

The CLT specimens are made of lamstock provided by Sutherland Timber Co.. The D.Fir lamstock was sourced from the Hanmer Springs area and is graded SG8. The CLT specimens were made with in the following layups and sizes shown in Table 1 below.

Table 1: CLT Specimens

CLT Type	Total Thickness (mm)	Lay-ups (mm)
3-Ply	60	20/20/20
	105	35/35/35
	135	45/45/45
5-Ply	175	45/20/45/20/45
7-Ply	275	45/35/35/45/35/35/45



The D.Fir lamstock was shipped to XLam NZ Ltd. In Nelson, New Zealand to be pressed into CLT panels. The following Table 2 outlines the widths and depths of boards sent to XLam:

**Table 2: CLT Lamstock Properties**

Layer Thickness (mm)	Board Width (mm)	Board Thickness (mm)
20	150+	25
35	200+	40
45	200+	50

In the production process at XLam, deficiencies in timber boards such as knots and slope of grain are removed and the boards are then finger-jointed by a mechanical press to lengths up to 15m. The jointed pieces are planed to laminations with precise dimensions of, for example, 20mmx150mm. The CLT panels are then made by placing the laminations in a vacuum press with Purbond clear polyurethane glue, which can produce panels of a maximum size of 15m x 3.4m. The glue is applied through a gravity feed mechanical system such that each layer of the CLT is face bonded to each adjacent board. The boards are not edge glued, though it is understood that some glue will make its way to the edges of the timber while under pressure. This edge gluing is not accounted for in structural design. However, it is understood that these gaps can help relieve the stresses due to differential shrinkage or swelling between the crosswise orientated layers and facilitate the pressing process. Figure 5 below shows a typical 5-ply CLT panel for reference.



**Figure 5: Cross-laminated Timber (CLT)**

### 3. DESCRIPTION OF TEST PROGRAMME

The test programme consists of mechanical property testing and dowelled connection testing. The material property testing include rolling shear and embedment strength testing and were carried out in the Model Structures Lab at University of Canterbury. The dowelled connection tests were carried out in the Structure Wing Lab at University of Canterbury.

#### 3.1 Short Bending Testing

Two types of CLT layup (35/35/35 and 45/45/45) were studied. In the following description, CLT35 will be used to refer to the specimens with 35 mm thick laminations; CLT45 refers to the specimens with 45 mm thick laminations.

The rolling shear (RS) strength properties were evaluated by three-point short-span bending tests, shown in Figure 6, following the test standard ASTM, D198-05a (2005). A total of 30 specimens in width of 50 mm were sampled from each type of CLT plate. The specimens were cut so that the face layers were parallel to the beam axis. They also had a small span-to-depth ratio of 6 in order to encourage the RS failures in cross layers. A loading rate was controlled so that the specimens could fail within approximately 10 minutes. Table 3 shows the configurations of the CLT plate including board grades, thickness of laminations, and plate dimensions.

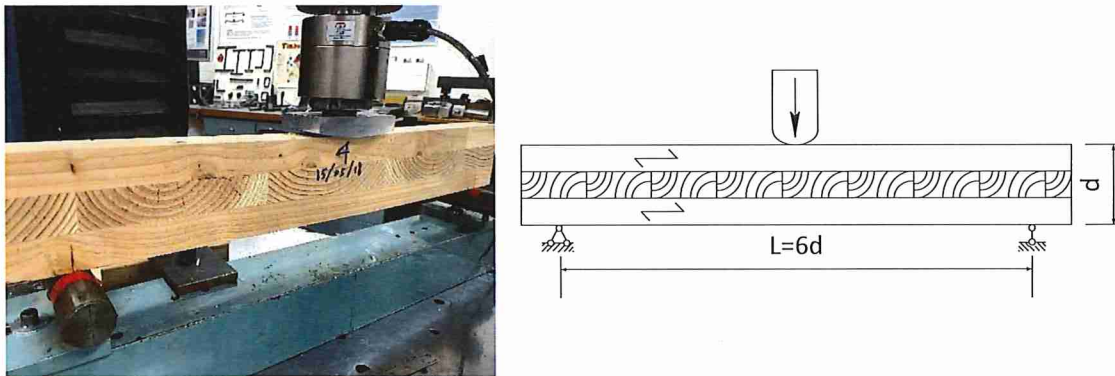

Figure 6 Short Bending Test

Table 3 Configuration of cross-laminated timber (CLT) specimens

CLT Lay-up	Lamination grade	Plate Dimension
------------	------------------	-----------------

		LxWxH (mm)
<b>CLT35</b>	SG8/SG8/SG8	735x50x105
<b>CLT45</b>	SG8/SG8/SG8	945x50x135

### 3.2 Embedment Strength Testing

A total of 30 half-hole embedment tests with  $d=12\text{mm}$  dowels were conducted according to ASTM D5764-97a (2013) on the CLT35. The specimens were sampled from full-size panels and had a width of 100 mm, a height of 100 mm, and a depth of  $L = 105\text{ mm}$ . See Figure 7 for reference. The specified average modulus of elasticity (MOE) of the SG8 laminations was 8 GPa for all three layers.

In order to avoid the bending deformation of the dowel fastener, load was applied using a stiffened dowel welded to a steel plate attached to the loading head of a hydraulic actuator. The specimen was loaded at a constant speed of 1.0 mm/min. The test was stopped when the resistance decreased to 80% of the peak load unless the displacement first reached 10.0 mm. The displacement was recorded by a Linear Variable Differential Transformer (LVDT) measuring the movement of the dowel.

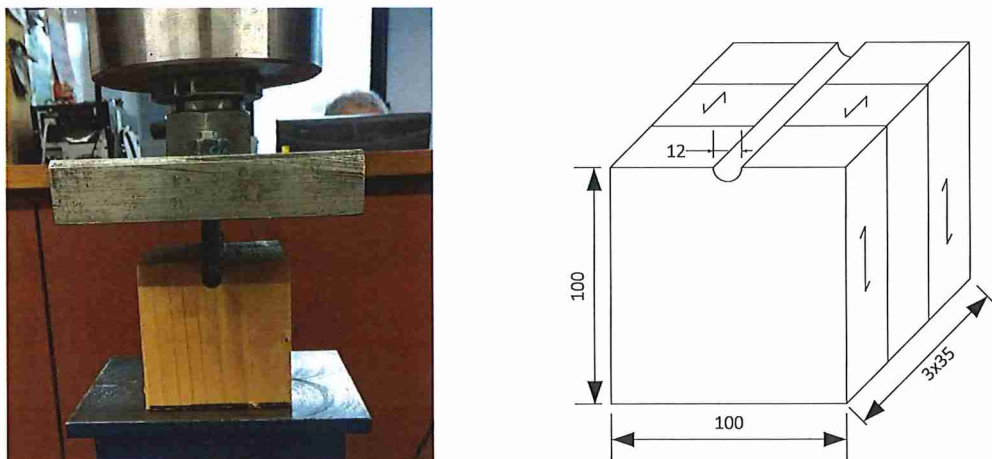

**Figure 7 Embedment Test Specimen Set-up**

### 3.3 Monotonic Dowelled Connection Testing

Monotonic dowelled connection tests were performed on 3-ply, 5-ply, and 7-ply CLT panels as shown in Table 4. The tests followed a constant loading rate as per ISO 16670:2003 (2003).

**Table 4: Monotonic Dowelled Connection Testing**

<b>CLT Panel Type</b>	<b>Dowel Diameter (mm)</b>	<b>Monotonic Tests</b>	<b>Modified Test</b>
<b>CLT 45 - 3-ply (45/45/45 – 135mm)</b>	12	3	1
<b>CLT 5 - 5-ply (45/20/45/20/45 – 175mm)</b>	20	3	1
<b>CLT 7 - 7-ply (45/35/35/45/35/35/45 – 275mm)</b>	20	3	1

The dowel spacing is a critical connection design parameter, and the monotonic testing followed spacing recommendations as per Eurocode 5 (2008) and the CLT Handbook (Gagnon, Pirvu, & Fpinnovations, 2011). Within the modified test, fully threaded screws were added to prevent brittle failure caused by the panels splitting, as this is a proposed economical solution after discussions with consulting engineers. Figure 8 and Table 5 show the spacing used in the testing. Previous dowelled connection testing with radiata pine CLT by Ottenhaus, Li, Smith, and Quenneville (2017) investigated smaller dowel spacing in order to investigate different failure modes. The purpose of this test programme was to extend the previous research by modifying the dowel spacing to achieve more ductile connections. For the CLT45 specimens, 12mm diameter dowels were installed in a tight fit 12mm diameter CLT hole and 14mm diameter steel plate hole to represent similar tolerances in practice. Similarly, for the CLT5 and CLT7 specimens, 20mm diameter dowels were installed in a tight fit 20mm diameter CLT hole and 22mm diameter steel plate. Refer to Appendix A, dowelled connection drawings, for further details.

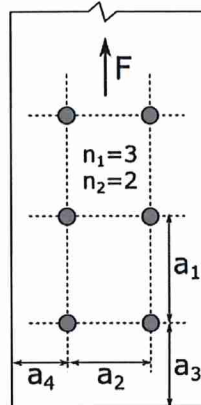

Figure 8: Dowel Spacing Identifiers  
(Ottenhaus, Li, Smith, & Quenneville, 2016)

Table 5: Dowel Spacing Requirements

Spacing Identifier	Spacing requirement in Eurocode 5 and CLT handbook		Spacing Used
a1	5d	Eurocode5	5d
	4d	CLT Handbook	
a2	4d	CLT Handbook	4d
	3d	Eurocode 5	
a3	Max (7d, 80mm)	Eurocode5	Max (7d, 80mm)
	5d	CLT Handbook	
a4	3d	Eurocode5	3d
	3d	CLT Handbook	

### 3.4 Cyclic Dowelled Connection Testing

Cyclic dowelled connection tests were also performed as part of the University of Canterbury 3<sup>rd</sup> Pro final year research project. The cyclic testing is in addition to the scope of the Phase 1 test work plan, and the test results will be provided upon completion of the 3<sup>rd</sup> Pro project in November 2018. Testing was performed on 3-ply CLT45, 5-ply CLT5, and 7-ply CLT7 specimens shown in

Table 6. Based on the dowel spacing recommended by Eurocode 5 and the CLT handbook in Table 5, a modified dowel spacing based on the recommendations from the previous testing by Ottenhaus (2016) was used. For this modified dowel spacing, a2 and a3 were increased to 6d and 9d respectively. The tests followed the test standard ISO 16670:2003 (2003).

Table 6: Cyclic Dowelled Connection Testing

CLT Layup	Dowel Diameter (mm)	EC/CLT Handbook Spacing Test	Modified Spacing Test
CLT45 - 3-ply (45/45/45 – 135mm)	12	5	5
CLT5 - 5-ply (45/20/45/20/45 – 175mm)	20	5	5
CLT7 - 7-ply (45/35/35/45/35/35/45 – 275mm)	20	5	5

### 3.5 Analytical Strength Predictions of Dowelled Connections

Analytical strength predictions based on Eurocode 5 and the CLT Handbook were made prior to tests. Dowelled connection strength calculation is a function of the embedment strength, dowel bending capacity, and timber member thickness, based on the following European Yield Model (EYM) formula provided in Eurocode 5 (British Standards, 2006):

$$F_{v,Rk} = \min \left\{ \begin{array}{l} f_{h,1,k} * t_1 * d \\ f_{h,1,k} * t_1 * d * \left[ \sqrt{2 + \frac{4M_{y,Rk}}{f_{h,1,k} * d * t_1^2}} - 1 \right] \\ 2.3 * \sqrt{M_{y,Rk} * f_{h,1,k} * d} \end{array} \right. \quad (1)$$

Where:

$F_{v,Rk}$  = characteristic load carrying capacity per shear plane per fastener

$f_{h,1,k}$  = characteristic embedment strength in the timber member

$t_1$  = thickness of the timber side member

$d$  = dowel diameter

$M_{y,Rk}$  = characteristic fastener yield moment

The embedment strength formula used for strength prediction was from the CLT Handbook and is as follows:

$$f_{h,1,k} = 0.031(1 - 0.015d)\rho_k^{1.16} \quad (2)$$

The capacity of the connections, for each CLT panel size, is provided in Table 7 below.

**Table 7: Analytical Strength Predictions**

CLT Panel Type	Dowel Diameter (mm)	Embedment Strength (MPa)	Connection Strength (kN)
<b>3-ply (45/45/45)</b>	12	30.4	85
<b>5-ply (45/20/45/20/45)</b>	20	26	167
<b>7-ply (45/35/35/45/35/35/4)</b>	20	26	210

## 4. EXPERIMENTAL RESULTS

### 4.1 Short Bending Testing

The CLT35 and CLT45 bending specimens typically failed in RS as shown in Figure 9. Shear cracks were initiated in the cross layers with an inclined angle mostly 40°–50° with respect to the beam axis and some of them were further propagated to the glue lines between the layers. Such a failure mode was very brittle. For the CLT35 specimens, 1 out of 30 specimens failed due to the tensile failure at the bottom edge of beam. For the CLT45 specimens, 2 out of 30 specimens experienced the tensile failures at the bottom edge.



Figure 9: Specimen failed in rolling shear (left)



Figure 10: Specimen failed in tension of bottom edge

In this study, shear analogy method developed by Kreuzinger (1999) for composite beams was used. This method takes into account shear deformations in cross layers. The stiffness values of the laminations used for the RS strength calculations are shown in Table 8 according to CLT Handbook (Gagnon et al., 2011).

Table 8: Input Stiffness Properties of CLT Laminations

Lamination Grade	$E_{\parallel}$ (Mpa)	$E_{\perp}$ (Mpa)	$G_0$ (Mpa)	$G_{RS}$ (Mpa)
SG8	8000	267	533	53

Figure 11 shows the cumulative distributions of the calculated RS strength values of the bending specimens. The statistic results of short bending testing are listed in **Error! Reference source not found.**. The RS failure load was taken as the peak load recorded during the test. The tensile failure specimens were removed from the statistical analysis. The CLT35 specimens with 35 mm thick laminations had significantly higher RS strength than the CLT45 specimens with 45 mm thick.



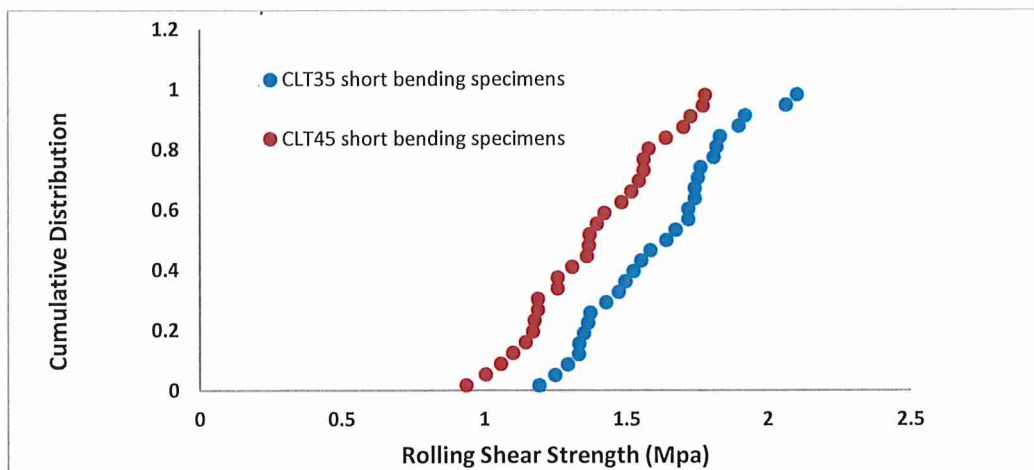

Figure 11: Cumulative Distribution of RS Strength of The Short Bending specimens

Table 9: Statistic Rolling Shear Testing Result

CLT Panel Type	Average density(kg/m <sup>3</sup> )	COV of density	Mean RS strength (Mpa)	COV of RS	Characteristic RS strength( Mpa)
CLT35	471.3	0.042	1.61	0.152	1.19
CLT45	476.9	0.054	1.38	0.173	0.94

#### 4.2 Embedment Strength Testing

In this testing, smooth dowels with 12 mm in diameter were used. The typical failure mode for most specimens was wood crushing under dowel bearing load, as shown in Figure 12. The test results in terms of density of wood and measured embedment strength are listed in

Table 10. Figure 13 shows the cumulative distributions of the embedment strength values.

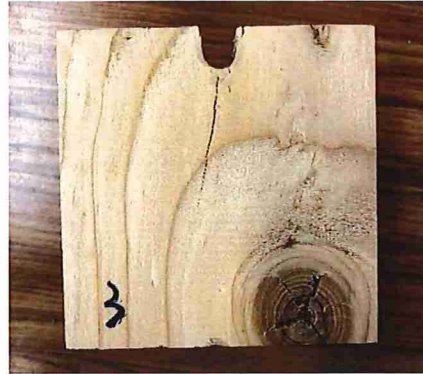

Figure 12: Failure of Embedment Specimen

Table 10: Density and embedment strength

CLT Panel Type	Avg. density( $\text{kg/m}^3$ )	COV of density	Characteristic density( $\text{kg/m}^3$ )	Avg. embedment strength (MPa)	COV	Characteristic embedment strength (MPa)
CLT35 with 12mm dowels	467.0	0.04	432.4	30.22	0.087	25.27

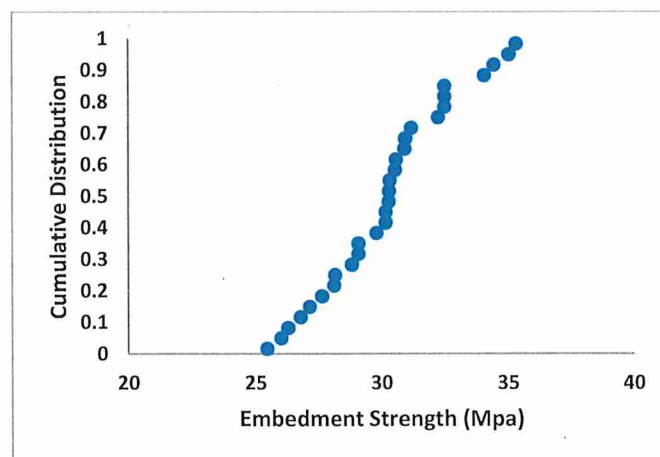
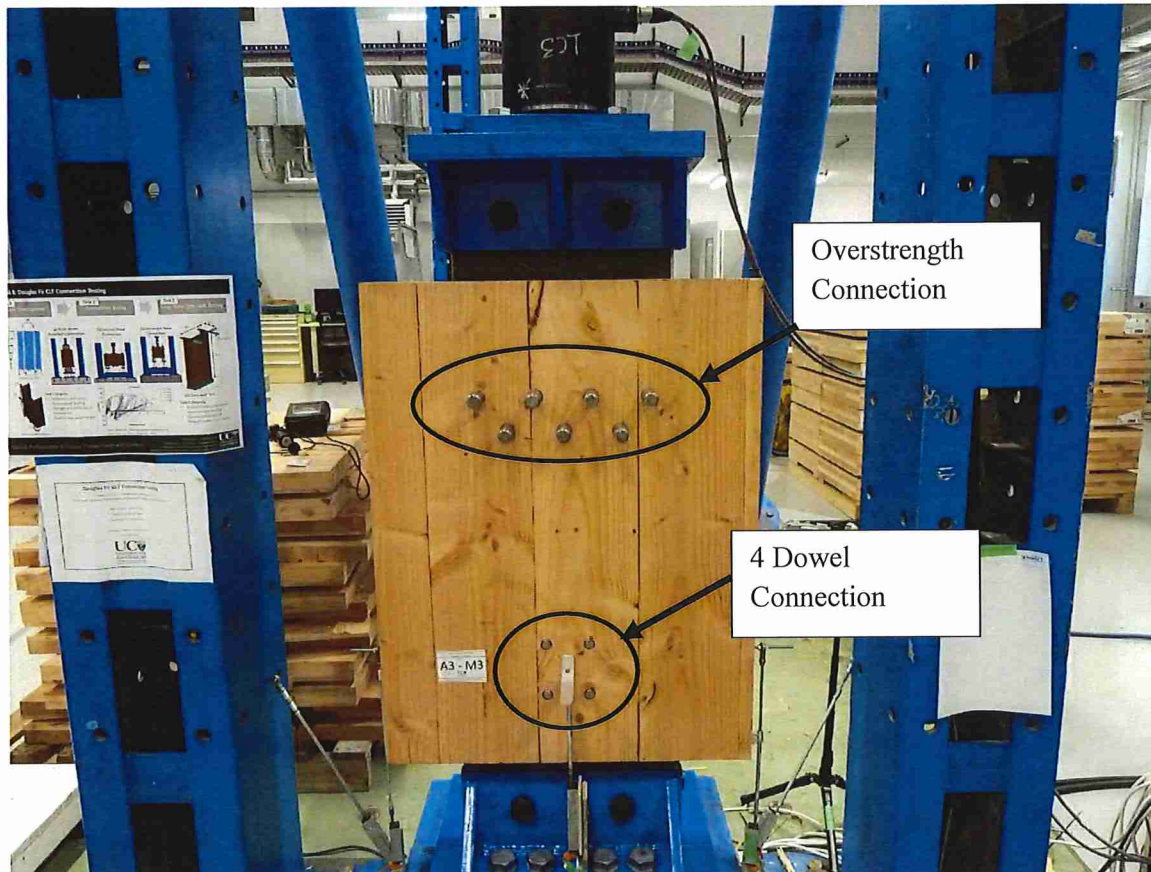

Figure 13 Cumulative Distribution of RS Strength of the Embedment Specimens

### 4.3 Monotonic Dowelled Connection Testing

All three CLT specimen sizes used the same testing frame for the test programme. Within the CLT specimens, the top connection was the overstrength connection (designed not to fail) and the lower connection was the connection to be tested. The tested connection has a group of 4 dowels. Structural drawings related to the dowel connection testing can be found in Appendix A.



In general, all specimens failed in significant dowel bending, wood local crushing around the dowels, and ultimately tensile splitting of the middle layers of the CLT. Though the ultimate wood failure is considered brittle, this occurred at very large displacements and the connections showed very ductile behavior.

a) *CLT45 - 3-Ply (45/45/45 - 135mm)*

Figure 14 and Figure 15 below show the typical failure modes of CLT45 at the ultimate stage, which are tensile splitting and row shear respectively. In general, the CLT specimens experienced ductile behaviour, which is shown in Table 11 below.



**Figure 14: CLT45 Tensile Splitting**



**Figure 15: CLT45 Row Shear**

This ductile behaviour can primarily be described as a combination of dowel bending and wood embedment crushing. This is shown in experimentally in Figure 16 and schematically in EYMVI of Figure 17 below.

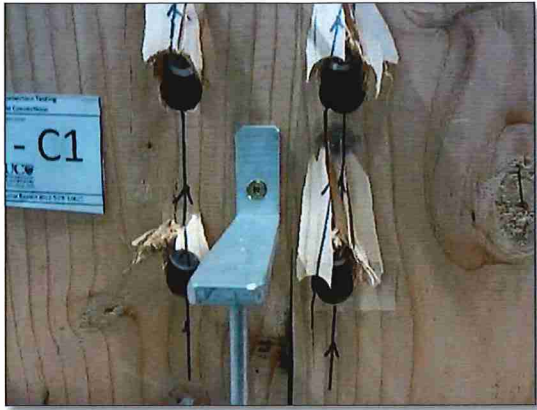

Figure 16: Dowel bending and timber crushing

When screws were added to the test specimen to prevent tensile splitting, more displacement was achieved in testing and brittle failure was avoided. This is shown in Figure 18 and Figure 19, displayed in red as A1-M4. A well defined row shear failure eventually developed in the specimen, however the inclined fully threaded screws prevented the brittle failure of mid layer caused by tension perpendicular to grain stresses.

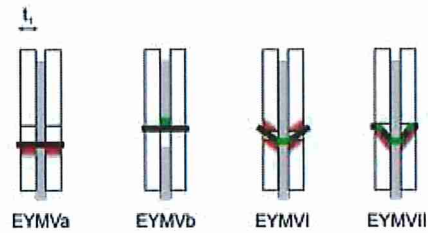

Figure 17: Failure modes EYM (Ottenhaus et al., 2016)



Figure 18: CLT45 Row Shear Failure

Figure 19: Load displacement curves of 3-Ply (135mm) CLT illustrates the Force-Displacement curves for the 4 test specimens.

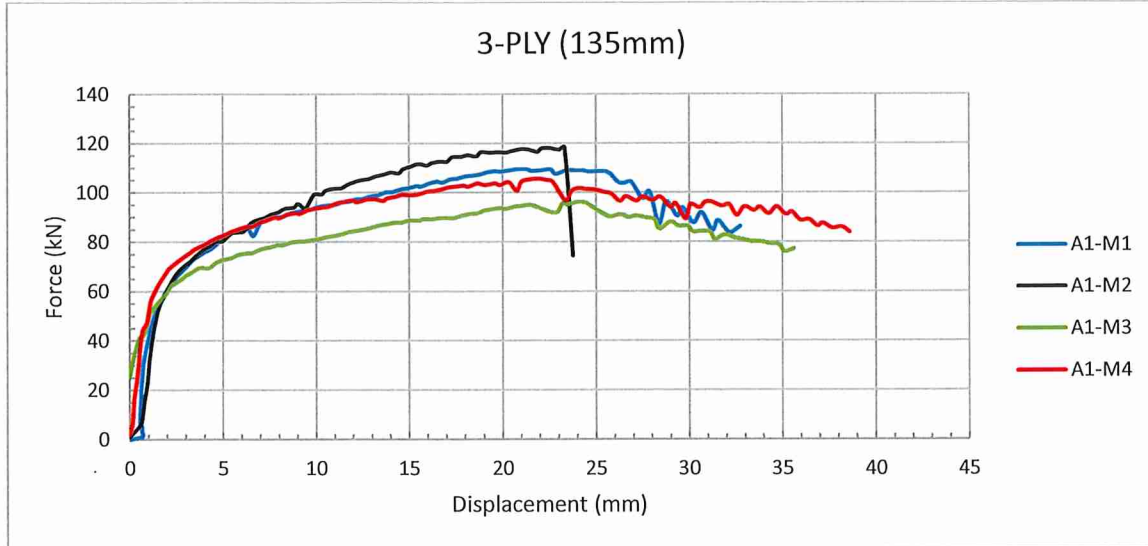

Figure 19: Load displacement curves of 3-Ply (135mm) CLT dowelled connections

b) CLT5 - 5-Ply (45/20/45/20/45 – 175mm) CLT

Similar to the three layered specimens, CLT5 specimens again generally failed with tensile splitting or row shear at ultimate loading stage, as shown in Figure 20 and Figure 21 below.

It is interesting to note specimen A3-M4, installed with the screws. As shown in Figure 22 and Figure 23 tensile splitting and row shear brittle failure were avoided as the screws successfully kept the panels together while sustaining the high loads. Figure 24 shows the 4 load displacement curves for the CLT5 specimens. From the figure, you can note the initial slip present due to the tolerances allowed for between the steel dowel and steel plate. All the specimens showed very ductile behavior with significant yield plateau.



Figure 20: CLT5 - Tensile Splitting



Figure 21: CLT5 Row Shear



Figure 22: Dowelled CLT5 connections with screws



Figure 23: Ultimate failure without tensile splitting

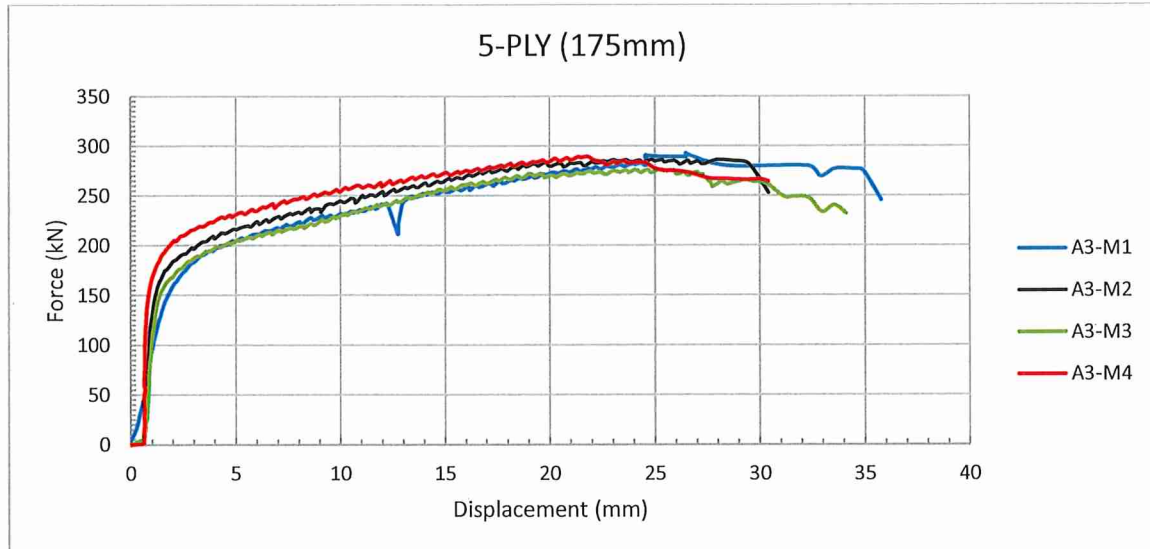

Figure 24: Load displacement curves of 5-Ply (175mm) CLT dowelled connections

c) CLT7 - 7-Ply (45/35/35/45/35/35/45 – 275mm)

CLT5 specimens again generally failed with tensile splitting at ultimate loading stage, as shown in Figure 25 and Figure 26. Figure 27 shows the 4 load displacement curves for the CLT5 specimens. All the specimens showed very ductile behavior with significant yield plateau.

Table 11 provides a summary of all the key data produced from the monotonic dowelled connection testing.





Figure 25: CLT7 Tensile Splitting



Figure 26: CLT7 Tensile Splitting

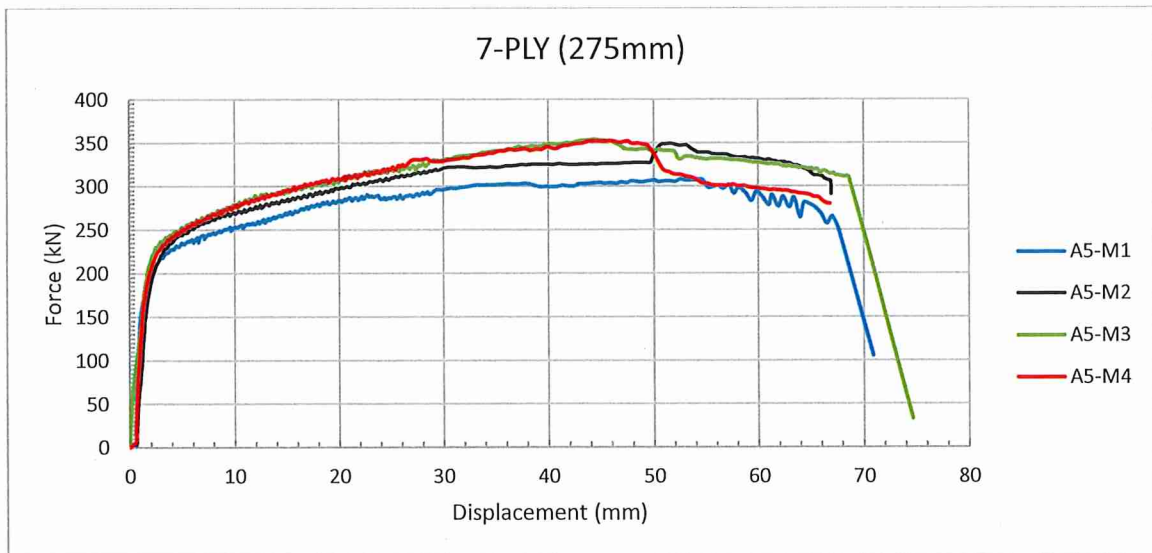

Figure 27: Load displacement curves of 7-Ply (275mm) CLT dowelled connections

**Table 11: Monotonic Dowelled Connection Testing**

Specimen	A1- M1	A1- M2	A1- M3	A1- M4	A3- M1	A3- M2	A3- M3	A3- M4	A5- M1	A5- M2	A5- M3	A5- M4
<b>F<sub>y</sub> (kN) Prediction</b>	86				167				210			
<b>F<sub>y</sub> (kN)</b>	80	80	72	84	209	210	202	225	256	258	263	264
<b>F<sub>max</sub> (kN)</b>	109.6	118.3	96	106	293	286	277	290	309	350	354	353
<b>F<sub>u</sub> (kN)</b>	87.68	94.64	77	85	246	253	233	267	250	291	310	280
<b>Δ<sub>y</sub> (mm)</b>	2.1	2.1	1.5	1.2	2.0	1.3	1.3	1.0	1.5	1.9	2.2	1.9
<b>Δ<sub>Fmax</sub> (kN)</b>	20.81	23.22	24	21	26	24	24	21	52	51	44	45
<b>Δ<sub>u</sub> (mm)</b>	30.2	24.6	36	38	36	29	34	29	67	66	69	66
<b>K (kN/mm)</b>	38.1	38.1	48	70	105	161	155	225	171	136	120	139
<b>MODE</b>	D	D	D	D	D	D	D	D	D	D	D	D
<b>μ1</b>	10	11	16	18	13	19	19	22	35	27	20	24
<b>μ2</b>	14	12	24	32	18	23	26	30	45	35	31	35

**Legend:**

- F<sub>y</sub>, F<sub>max</sub>, F<sub>u</sub> Yield strength, maximum load, and load at ultimate displacement respectively
- Δ<sub>y</sub>, Δ<sub>Fmax</sub>, Δ<sub>u</sub> Yield displacement, displacement at maximum load, and ultimate displacement respectively
- K Stiffness (kN,mm)
- MODE Failure Mode: B – Brittle, M – Mixed, D – Ductile (Smith, Asiz, Snow, & Chui, 2006)
- μ1, μ2 Ductility, as defined by Smith et al. (2006) and (British Standards, Technical Committee B, & British Standards Institution. Technical Committee B, 2005)

#### **4.4 Cyclic Dowelled Connection Testing**

The cyclic dowelled connection testing will be reported upon completion of the University of Canterbury 3<sup>rd</sup> Pro final year project. Results will be provided in the 2018-2019 project report.

## **5. CONCLUSIONS**

Rolling shear strength properties, embedment strength properties of 3-ply D.Fir CLT products made from NZ grown Douglas-fir timber were evaluated experimentally in this project. Short-span bending with a span-to-depth ratio of 6 was used to encourage rolling shear failure mechanism in the cross layers of CLT. The thickness of the laminations was 35 mm and 45 mm in order to consider the effect of lamination thickness on the rolling shear strength properties. The preliminary test results indicated that the characteristic rolling shear strength values of the D.Fir CLT with 35 mm and 45 mm laminations (1.19 MPa and 0.94 MPa, respectively) were slightly lower than that of Radiata pine CLT. However, it is within a normal range of softwood CLT products from Europe and North America (0.5 MPa ~ 1.1 MPa).

Dowelled connections in the D.Fir CLT with different layups (3-ply, 5-ply and 7-ply) were also evaluated experimentally. Based on previous research finding on the dowelled connections in Radiata pine CLT, an improved connection layout with increased dowel spacing was used in the design of the connection specimens. The test results showed that the capacity of the 3-ply connections agreed well with the analytical predictions based on Eurocode 5. The actual capacity of the 5-ply and 7-ply connections was significantly higher than the analytical predictions based on Eurocode 5. More importantly, all these connections under monotonic loading showed very ductile behavior with ductility ratios exceeding 12, indicating the great potential of dissipating energy under seismic loading. The results of the connection behavior under cyclic loading will be processed and reported in the next project report.

## **ACKNOWLEDGMENTS**

The authors would like to thank University of Canterbury technician Mr. Gavin Keats for his valuable input in the design of the dowelled connection test frame, manufacturing of ongoing assistance throughout the test programme. The authors would also like to thank University of Canterbury 3<sup>rd</sup> Pro students Mr. Chengzhang Wang and Ms. Weijie Xu for their work on the rolling shear and embedment testing, and Mr. Chris Ravn and Mr. Ben Scott for their work on the dowelled connection testing.

## REFERENCES

- ASTM, D198-05a, (2005), “Standard test method of static tests of lumber in structural sizes.” ASTM International, West Conshohocken, PA, United States
- ASTM D5764–97a (2013) “Standard test method for evaluating dowel-bearing strength of wood and wood-based products”. ASTM International, West Conshohocken, PA, United States
- European Standard EN 1995-1-1 2004/A1 2008 Eurocode 5 (2008). “Design of timber structures - part 1-1: general- common rules and rules for buildings/incl Amendment A1.” European Committee for Standardization, Bruxelles, Belgium.
- 16670:2003, I. (2003). Timber Structures - Joints made with mechanical fasteners - Quasi-static reversed-cyclic test method. *The International Organization for Standardization, Geneva.*
- British Standards, I. (2006). *Eurocode 5: design of timber structures.* London: BSI.
- British Standards, I., Technical Committee B, S. t. S. B. T. m., & British Standards Institution. Technical Committee B, S. t. (2005). *Timber structures: test methods : cyclic testing of joints made with mechanical fasteners : [including amendment A1:2005]* (English version. ed. Vol. BS EN 12512:2001.;BS EN 12512:2001;). London: British Standards Institution.
- Gagnon, S., Pirvu, C., & Fpinnovations. (2011). *CLT handbook: cross-laminated timber* (Canadian ed. Vol. SP-528E.;SP-528E;). Québec: FPInnovations.
- Green, M. (2017). *The case for tall wood buildings: how mass timber offers a safe, economical, and environmentally friendly alternative for tall building structures* (2nd ed.). British Columbia: MGA.
- Kreuzinger, H. (1999). Platten, Scheiben und Schalen—ein Berechnungsmodell für gängige statikprogramme. *bauen mit holz, 1*, 34-39.
- Ottenhaus, L. M., Li, M., Smith, T., & Quenneville, P. (2016). *Ductility and overstrength of dowelled LVL and CLT connections under cyclic loading.* Paper presented at the WCTE 2016 - World Conference on Timber Engineering.
- Ottenhaus, L. M., Li, M., Smith, T., & Quenneville, P. (2017). Overstrength of dowelled CLT connections under monotonic and cyclic loading. *Bulletin of Earthquake Engineering*, 1-21. doi:10.1007/s10518-017-0221-8
- Pachauri, R. K., & Reisinger, A. (2007). IPCC fourth assessment report. *IPCC, Geneva, 2007.*
- Page, I. (2017). *Medium-density housing supply and demand analysis* (SR379). Retrieved from Porirua, New Zealand:
- Smith, I., Asiz, A., Snow, M., & Chui, Y. H. (2006). Possible Canadian / ISO Approach to Deriving Design Values From Test Data. *CIB W18 Meeting Thirty-Nine Florence, (August).*

**APPENDIX A: DOWELLED CONNECTION DRAWINGS**

NOTES:  
 1. ALL DIMENSIONS ARE IN MILLIMETERS U.N.O.  
 2. MAX. TESTING LOAD - 500 kN

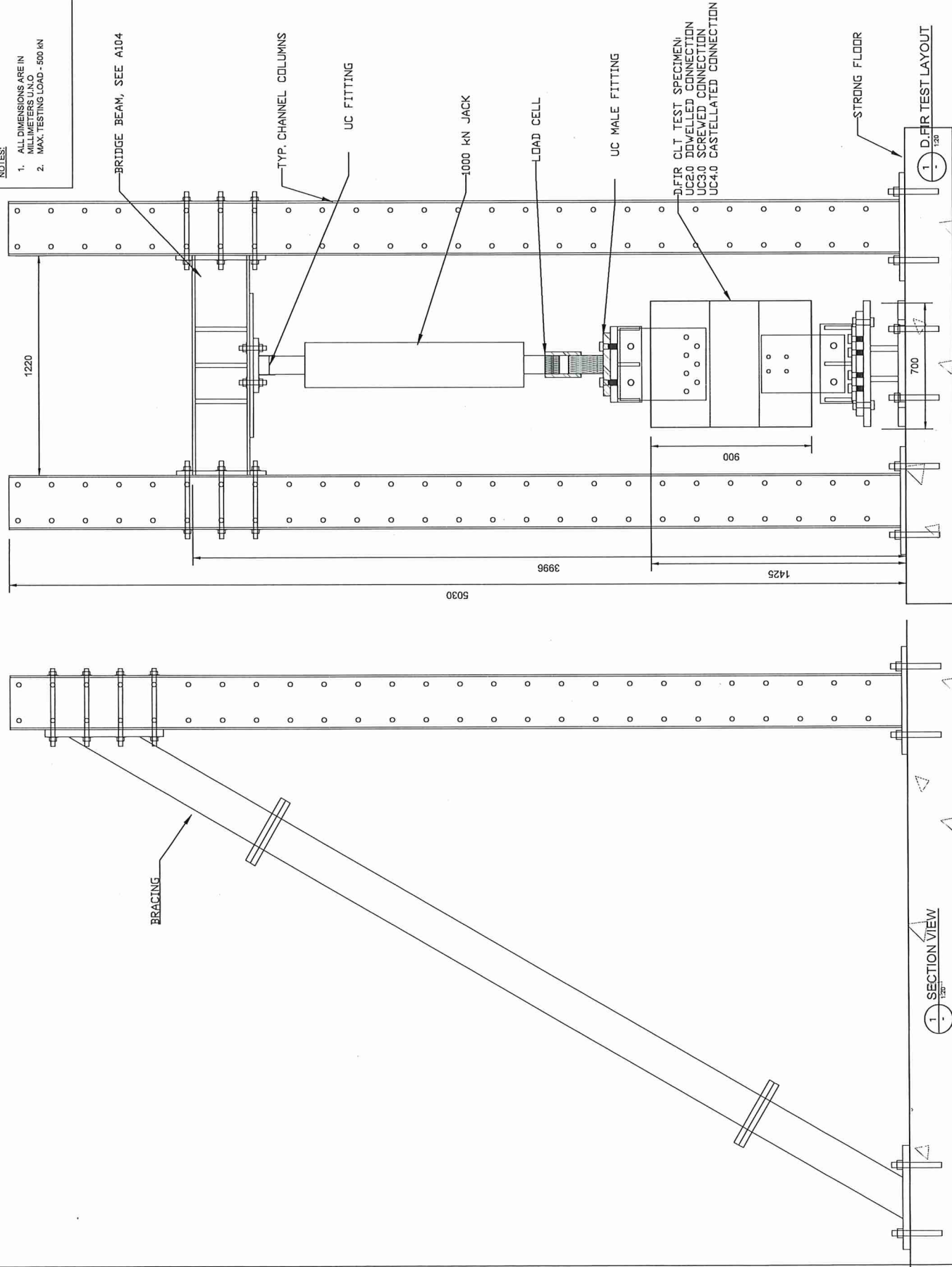

REV.	DESCRIPTION	DATE	ISSUED
D	IFC	2018-04-13	
C	IFR	2018-05-27	
B	IFR	2018-05-28	
A	IFR	2017-11-27	



CLIENT DOUGLAS-FIR ASSOCIATION  
 PROJECT D.Fir Connection Testing

TITLE  
 Test Layout

DRAWN: JB	JOB No. UC-101
CHECKED: ML	REVISION
DATE: 2017-11-27	
DWG. No.	

**UC1.0**

1 SECTION VIEW  
 1/200

1 D.FIR TEST LAYOUT  
 1/200













**NOTES:**  
 1. ALL DIMENSIONS ARE IN MILLIMETERS U.N.C.  
 2. ALL DIMENSIONS ARE IN MILLIMETERS U.N.C.  
 3. ADDITIONAL TESTS OF EITHER FULLY THREADED SELF-TAPPING SCREWS OR WASHER AND BOLT COMBINATIONS WILL BE PERFORMED IF TIME WITH EXTRA ASSEMBLIES.

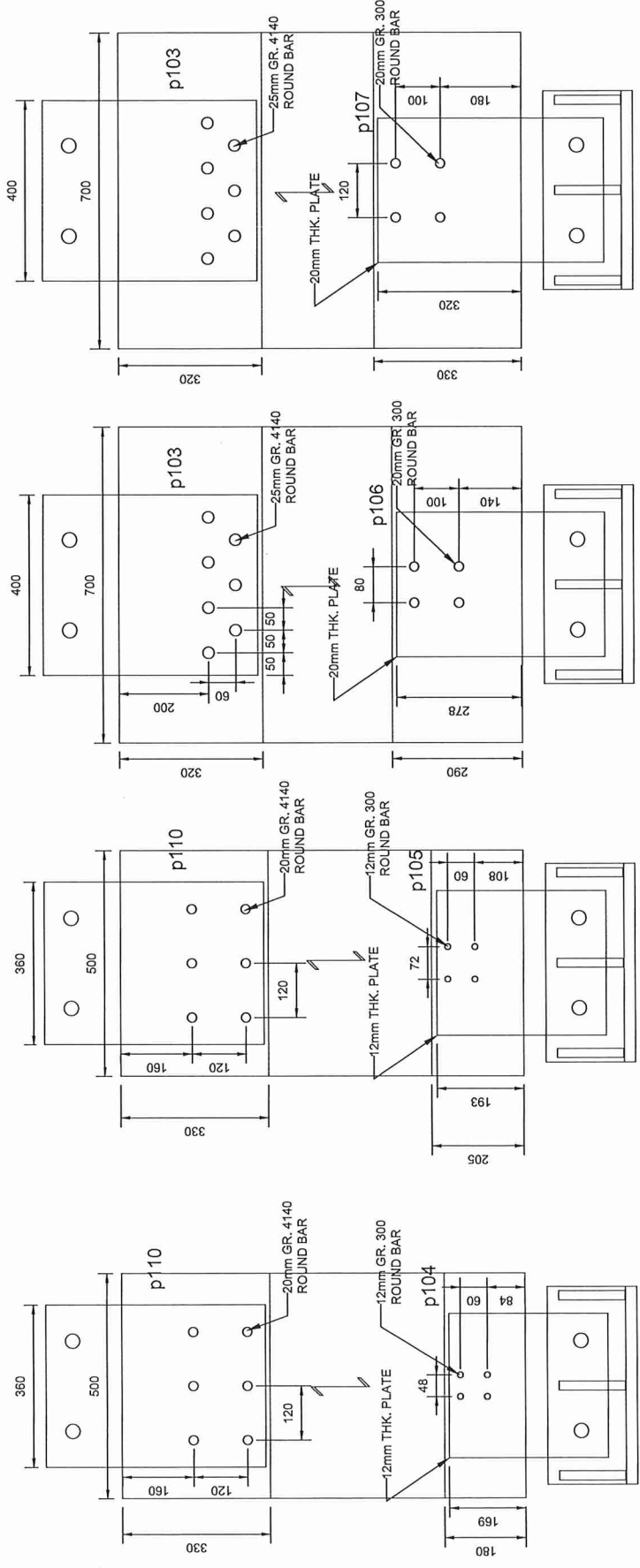

REV.	DESCRIPTION	ISSUED
A	IFR	
0	IKC	
	2018-04-03	
	2018-02-05	
	DATE	



1 - 3-PLY EC TEST

**A1 ASSEMBLY:**

MONTONIC - 3 TESTS  
 CYCLIC - 5 TESTS

ORDERED ASSEMBLIES - 10

2 - 3-PLY MOD. - EC TEST

**A2 ASSEMBLY:**

MONTONIC - 0 TEST  
 CYCLIC - 5 TESTS

ORDERED ASSEMBLIES - 6

3 - 5 AND 7-PLY EC TEST

**A3 ASSEMBLY (5-PLY):**

MONTONIC - 3 TESTS  
 CYCLIC - 5 TESTS

ORDERED ASSEMBLIES - 10

4 - 5 AND 7-PLY MOD. - EC TEST

**A4 ASSEMBLY (5-PLY):**

MONTONIC - 0 TEST  
 CYCLIC - 5 TESTS

ORDERED ASSEMBLIES - 6

TITLE  
 TEST SETUP ASSEMBLY

DRAWN: JB	JOB No. UC-101
CHECKED: ML	REVISION
DATE: 2018-02-15	Δ
DWG. No.	

**UC2.2**

CLIENT  
 DOUGLAS-FIR ASSOCIATION

PROJECT  
 D.Fir Connection Testing